

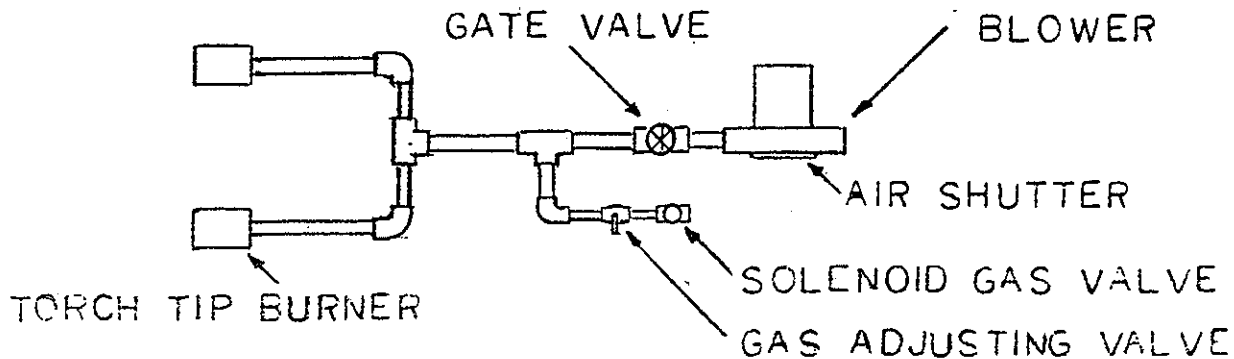

**JOHNSON POWER  
BURNER  
INSTRUCTION MANUAL**

LIGHTING INSTRUCTIONS FOR NO. 323 POWER  
BURNER WITH BASO SWITCH SAFETY



1. The gas adjusting valve should be closed. Fully open the blower air shutter. Open the gate valve 2 or 3 full turns from the closed position.
2. Open one of the pilot gas valves. Depress the red lever on the Baso switch and ignite the pilot burner. Keep the lever depressed until the pilot has burned for 40 seconds. Release the lever and the pilot should remain burning. If not repeat lighting.
3. Repeat step 2 for the other pilot burners.
4. Turn the wall switch to "on". The blower motor should be running and the solenoid gas valve should be open. Slowly open the gas adjusting valve just to the point where the burners ignite. Make gradual adjustments to this valve to obtain the desired flame.
5. To increase the amount of gas, increase the opening of the gate valve and the gas adjusting valve.
6. To decrease the amount of gas, decrease the opening of the gate valve and the gas adjusting valve.
7. To shut down the burners, turn the gas adjusting valve off and then turn the wall switch off. If desired, the gas adjusting valve can be left in the adjusted position and the main gas shut-off valve turned off.

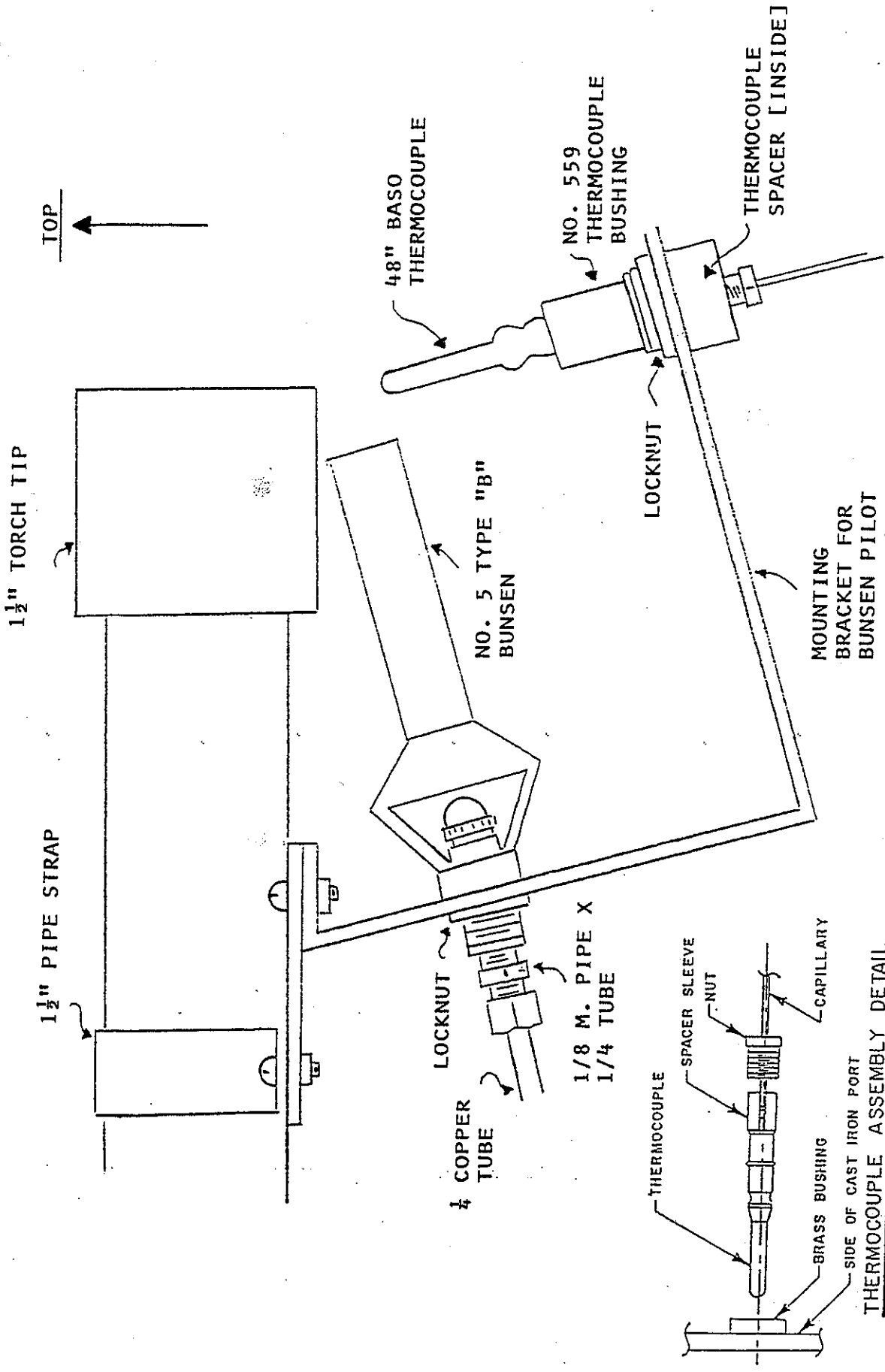

ASSEMBLY OF BUNSEN PILOT ON POWER BURNER

PIPING DIAGRAM

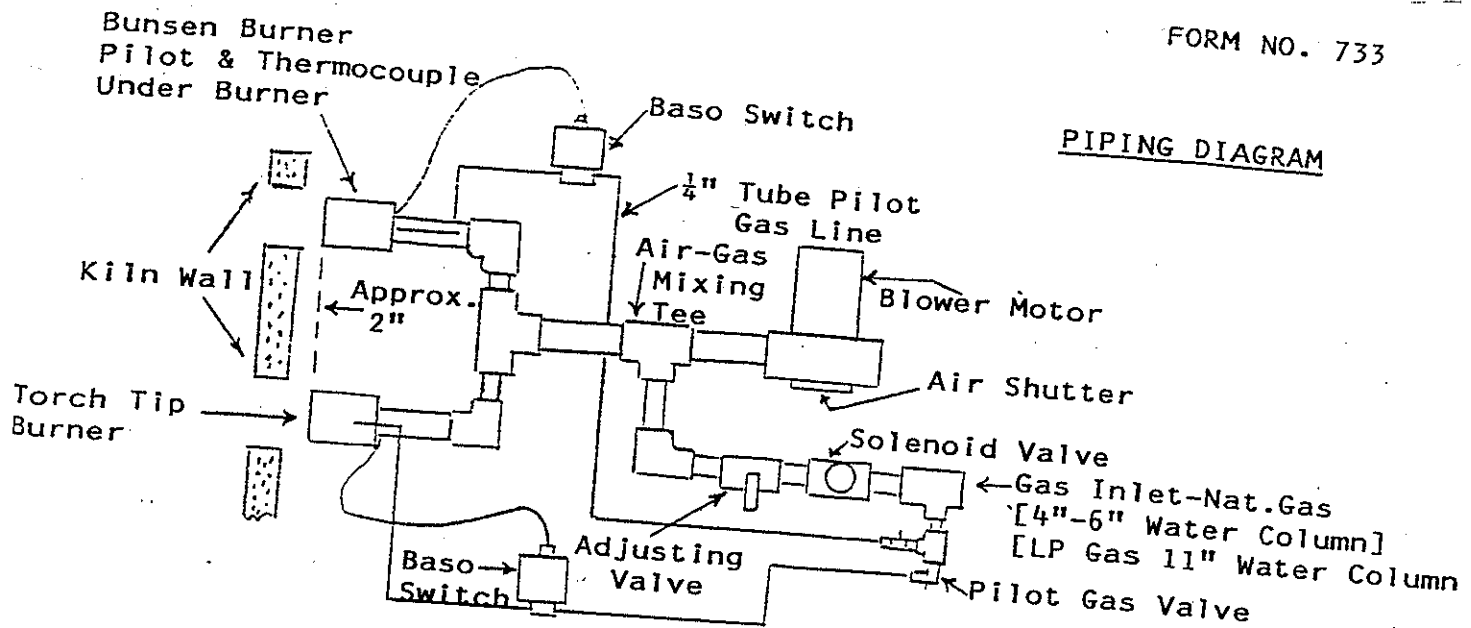

WIRING DIAGRAM

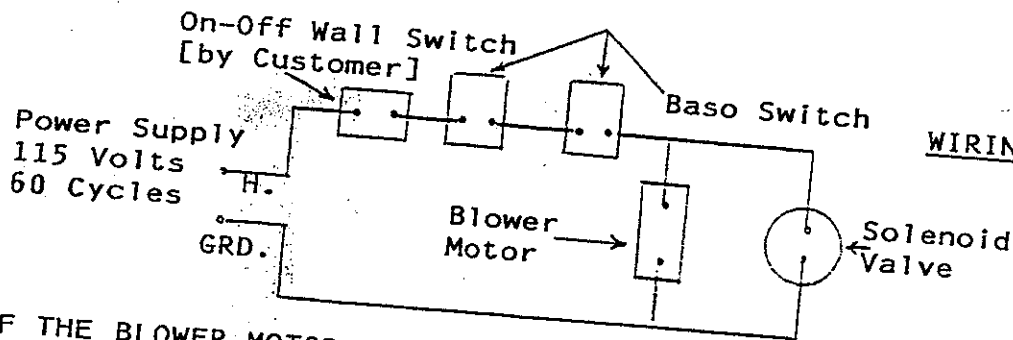

NOTE: IF THE BLOWER MOTOR HAS TWO LEADS COMING FROM IT - USE THE WIRING DIAGRAM ABOVE.  
IF IT HAS THREE LEADS, USE WIRING DIAGRAM SHOWN BELOW.

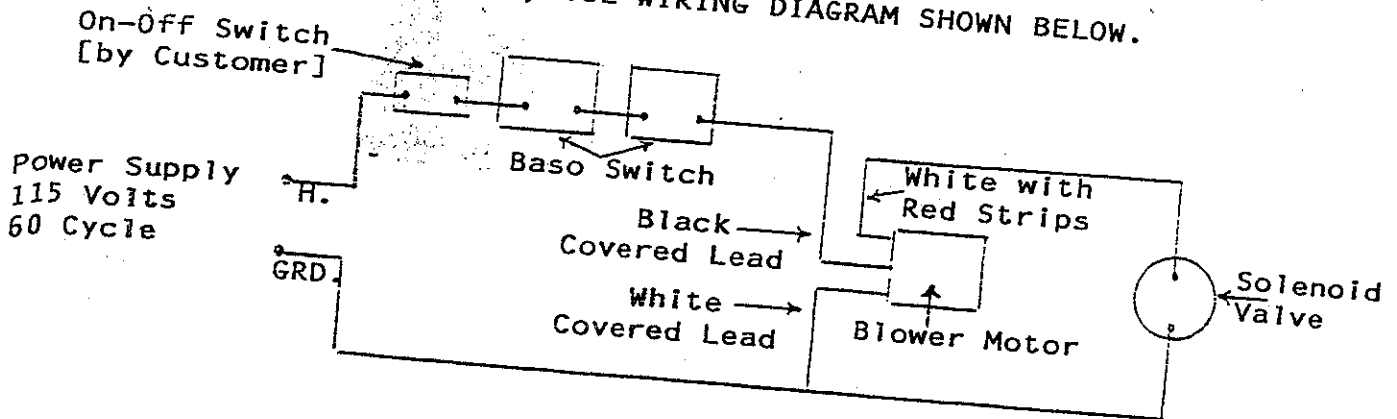

# MAINTENANCE INSTRUCTIONS FOR JOHNSON FURNACES

Johnson equipment is designed to give the longest possible service at the lowest maintenance cost. Due to the high temperatures reached by Johnson furnaces certain repairs are required from time to time to keep them in good operating condition. We are listing below pertinent maintenance information.

## OVEN TYPE HEAT TREATING FURNACES [#70, #120, #121, #142, #143, #654, #706]

### A. GENERAL MAINTENANCE:

These furnaces are lined with high temperature insulating refractory. This refractory expands and contracts as the furnace heats and cools; and cracks will appear throughout the lining. These are normal and should not be cause for alarm and should NOT be filled with cement as it will cause the brick to spall. The door brick on the #70, #120, #121 & #654 furnaces should be replaced occasionally. It is furnished with inconel screws and washers to withstand the high temperatures. The door should NOT be used as a shelf or parts dragged across the door brick in the process of removing parts from the furnace. Also, avoid striking the sides of the furnace with tongs. The hearth plate will require replacement occasionally, as will the front and back hearth rests on which the plate is set. The hearth plate must be used with the channel edges up. Parts to be heated should be pre-heated or brought up to temperature with the furnace when possible; avoid placing a cold piece on a hot hearth plate. When the gas is turned off to the furnace, turn off the blower at once so the lining will cool gradually.

### B. FURNACE RELINING AND FURNACE EXCHANGE:

The furnace should be used until the complete lining is considerably deteriorated. It should then either be replaced with a new lining or new furnace body from the factory. Complete sets of fire brick linings with special shapes to fit the furnace and cement for sealing the brick are available with easy-to-follow installation instructions. Many operators, however, prefer to take advantage of the special price on replacement furnace bodies. Check our repair parts list for prices. This method is popular because it insures an expertly relined furnace in operation at all times; it eliminates the time and trouble of relining the furnace in the customer's shop; and it eliminates the "down" time for returning to the factory for relining. WHEN ORDERING, SPECIFY IF FURNACE IS TO HAVE SAFETY PILOT PORT INSTALLED. FOR ADDITIONAL INFORMATION ON SAFETY EQUIPMENT SEE PAGE 3.

### PYROMETER EQUIPMENT:

Occasional replacement must be made of the thermocouple elements, the protection tubes or of the complete thermocouple assembly. We carry replacement parts in stock for immediate delivery.

POT TYPE FURNACES [#920, #950, #568, #580, #565, #565A, #521, #575, #575A, & #575B]

A. FURNACE RELINING:

These furnaces are lined with a high-quality, wear-resistant, castable lining poured with molds used in our factory. These linings are very rugged, and the furnaces should be used until the linings are considerably deteriorated, and then replaced with new furnace bodies. The new bodies are furnished complete less blower equipment and pots or crucibles. Prices for the new bodies are given on the repair parts list. With this method the customers are assured of an expertly lined furnace; and they are never without a furnace to use in their shops. If the lid lining needs replacement before the furnace body, material can be supplied to be mixed with water and molded into the furnace lid or a refractory lid can be supplied.

B. FURNACE RELINING #900 CRUCIBLE FURNACE:

This furnace is lined with a precast lining that can be replaced in the shop or a new replacement body can be supplied.

C. USE OF POTS:

DO NOT use a pressed steel pot for melting aluminum. A graphite crucible is used in the crucible furnaces. A cast iron pot is also suitable when contamination of aluminum by the cast iron is not objectionable.

To extend pot life carry a neutral or slightly reducing flame [more gas than air]. A flame that is too blue is oxidizing and will cause rapid scaling of the pot.

Avoid infiltration of cyanide or other salts into the combustion chamber. If seepage or splashing is occurring, place a ring of dry, powdered fire clay under the flange of the pot.

Turn the pot a little each day so that a different part is exposed to the hottest gases.

Remove sludge or sediment from pot at least once a day. This acts as an insulator, causing local overheating of pot.

Remove the pot at regular intervals and thoroughly clean the inner surface. Also hammer off thin scale that forms on outside.

D. USE OF CRUCIBLES:

Crucibles should be kept in a warm, dry area. Before using a new crucible anneal it by placing it in a warm furnace and gradually raising the temperature at about five minute intervals over a period of forty five minutes until the crucible becomes red.

BLOWER MOTORS:

Motors on the blowers should be oiled occasionally. The brushes should be checked and replaced periodically to avoid wear on the armature.

FORGE FURNACES [#122 & #133]

The forge furnaces are lined with hard firebrick on all wearing surfaces. Individual firebricks can be easily replaced when desired. Lining for the lid or complete lining can be replaced when necessary. Sets of linings are furnished with simple instructions for installation.

SOFT METAL MELTING FURNACES [#379, #313 & #616]

A. FURNACE RELINING:

These furnaces can be relined with brick and castable material supplied by our Company. An instruction sheet accompanies the shipment.

B. GENERAL MAINTENANCE:

Avoid permitting metal to solidify in the pots. If the metal does "freeze" in the pot, turn one burner only on until the metal melts slowly; do not turn all burners on at once or the pot will crack. When melting metal, let small amount of metal form a molten pool before adding additional metal.

SMALL BENCH FURNACES [#101, #112, #108 & #118]

The burner tubes on these furnaces are slotted on the ends to retain the flame, and care should be taken about striking the ends with soldering irons. These tubes are made of cast iron and will give long service, but when the slots are knocked off, the tubes should be replaced to insure good combustion. The #108 and #118 furnaces are equipped with individual valves for each burner. The #101 and #112 furnaces are equipped with double valves. After considerable use the valve plugs will tighten causing the valves to "freeze". When this happens the complete valve will should be replaced as prompt replacement of the complete valve will avoid gas leakage. Linings for all these furnaces are carried in stock. Lining sets are supplied for those in which both hood and bottom are lined. This set consists of material to be molded in to the furnace body and includes a new angle iron.



**APPROVED COMPONENTS FOR INDUSTRIAL FURNACES**

Approved components used on our industrial furnaces and power burners with flame rod or thermocouple safety and ultra-violet safety.

JOHNSON PARTS	APPROVAL		
	UL	CSA	OTHER
Baso Switch	√		
Baso Valve		√	AGA
Baso Thermocouple			AGA
Baso Pilot w/Orifice		√	AGA
Air Switch	√		
ITT Solenoid Valve	√		Factory Mutual
Transformer	√	√	
Lock Out Light	√		
Ignition Button	√	√	
1/30 Motor Bodine	√	√	
1/7 Carter Motor	√		
1/3 Motor w/ back Contact	√		
P & B Relay	√	√	
Speed Control Switch	√	√	
Start - Stop Switch			Top/Application Only
Ignition Wire	√		
All Other Wire	√		
3/4 Gas Pressure Regulator			AGA
OJ21 Ignitor Plug	√		
Gas Adjustment Valve	√		
Fireye Control	√		
Flame Rod 12"	√		
Scanner	√		

NOTE: All Johnson Gas Industrial Furnaces are factory tested for proper function of all systems and all piping is leak tested.

JOHNSON GAS APPLIANCE COMPANY • 520 E AVENUE N.W. • CEDAR RAPIDS, IOWA 52405

1-800-553-5422 • 319-365-5267 • FAX 319-365-6282





## WARRANTY

We warrant our equipment to be free of workmanship or material defects. Should any material prove defective within one year after shipment due to faulty material or improper workmanship we will furnish without charge to the original purchaser, replacement or repair of said defective part or parts returned freight prepaid to Johnson Gas Appliance Company, Cedar Rapids, Iowa. The foregoing shall not apply to equipment that has been altered or repaired after shipment to you by anyone except our authorized employees, and the Company will not be liable in any event for alterations or repairs except those made with its written consent. On material not of our manufacture, the manufacturer's guarantee to us is extended. This paragraph does not cover ordinary wear and tear, corrosion or improper handling or storage after leaving our point of shipment. If inspection by the Company does not disclose any defect in workmanship or material, the Company's regular charges will apply. Any refractories supplied with this order will be warranted as to quality and will be selected in accordance with good practice for the service intended. The foregoing obligations are in lieu of all other obligations and liabilities including negligence and all warranties, or merchantability or otherwise, express or implied in fact or by law, and state our entire and exclusive liability and buyer's exclusive remedy for any claim or damages in connection with the sale or furnishing of goods or parts, their design, suitability for use, installation or operation. We will in no event be liable for any special or consequential damages whatsoever, and our liability under no circumstances will exceed the contract price for the goods for which liability is claimed.

JOHNSON GAS APPLIANCE COMPANY • 520 E AVENUE N.W. • CEDAR RAPIDS, IOWA 52405

1-800-553-5422 • 319-365-5267 • FAX 319-365-6282

Manufacturers since 1901 / Heat Treating Furnaces / Industrial Gas Burners / Stock Tank Heaters / Concrete Curing Systems

No 34, 321, 342, 323, 345 Kiln Adjustable

Power Burner

- 75-01-00024\* 1-1/2" Torch Tip with 7/8" Bore Plain
- LA-01-00104 1 1/2" Torch Tip 7/8 Bore machined for Electric Ignition and Flame Rod Safety
- LA-01-00011\* 2" Torch Tip with 1-1/4" Bore Plated
- LA-01-00002 Pilot Bunsen Burner Tube
- 05-07-00008 48" Baso Thermocouple
- 65-08-00040 #559 Thermocouple Bushing
- HA-01-00361 Thermocouple Spacer
- 65-06-00040 Ignitor Plug OJ-21-4
- 65-08-00030 Ignitor Plug Adaptor
- 65-02-00010 Washer
- 10-10-00047 Baso Switch L62GB01
- 15-01-00008 1/3 HP Motor w/Back Contact Switch
- BA-01-00002 #1203 Blower
- BA-01-00003 #1204 Blower
- 05-02-00114 1" Gate Valve
- 05-02-00113 1-1/2" Gate Valve
- 05-02-00022 1" Solenoid Valve K3A
- 05-02-00155 Straight Pilot Valve
- HA-04-00502 48" Length of Pilot Tubing
- 05-06-00014 69 NDI Flame Rod - 12" Long
- HA-04-00503 3/8" x 5' Air Line w/3/8" Compression Nuts and Sleeves
  
- HA-04-00504 5' Long 14 Gauge Ground Leads w/Terminal Connectors
- 05-06-00067 Fireye TFM-ID Flame Safeguard - Replacement
- SA-03-00002 Flame Rod Bracket
- 05-06-00013 Fireye Base
- 05-06-00056 MP100 Programmer
- 05-06-00057 Amplifier Mart 1T
- 10-10-00071 Eaton 140-48 Air Switch
- 05-05-00001 Ignition Transformer
- 10-10-00012 P and B Kup Relay - DPDT
- 10-10-00007 Cutler Hammer 10250H-2727A Start Stop Station
  
- HA-06-00254 Lock Out Light
- 05-02-00166 1" Gem Ball Valve
- 05-02-00103 3/4" Gem Ball Valve
- HA-04-00133 1 1/2" Mixing Tee
- SA-01-00077 1" Mixing Tee
- 05-02-00021 3/4" K3A Solenoid Valve
- HA-04-00514 Pilot Assy. Bunsen Type
- LA-01-00010 No. 34 Torch Stand
- HA-04-00506 Ignition Lead 5' Long w/Connectors
- HA-04-00506 Flame Rod Lead - 5' Long w/Connectors
- 10-06-00043 Ignition Boot
- 10-06-00044 Insert for Ignition Boot
- 10-06-00045 Connector for Ignition Boot
- 10-02-00002 Ignition/Flame Rod Lead Wire (per foot)

2" Plain Torch Tip  
w/1 1/4" Bore  
75-01-00025