



JOHNSON GAS APPLIANCE COMPANY
Cedar Rapids, Iowa

INSTRUCTION MANUAL

LOST WAX / SHELL BURNOUT FURNACE
WITH DIRECT SPARK IGNITION AND FLAME ROD SAFETY

FORMS A-2087 -- 1222-B -- 585-A -- 583-B
1173-B -- 1191R2 -- A-2086 -- MAINT. INST.

36" LOST WAX/SHELL BURNOUT FURNACE CHECK OFF LIST

SHIPPED	REQUIRED	DESCRIPTION
_____	<u>1</u>	FURNACE BODY COMPLETE WITH LID - WAX TUB - RACK - BURNERS.
_____	<u>1</u>	SIMPSON METER.
_____	<u>1</u>	12' THERMOCOUPLE LEAD WIRE.
_____	<u>1</u>	8" C/A THERMOCOUPLE WITH INCONEL PROTECTION TUBE.
_____	<u>1</u>	INSTALLATION & OPERATION MANUAL.
_____	<u>1</u>	12" BODY EXTENSION - <u>IF ORDERED</u>
_____	<u>2</u>	POWER BURNER AS SPECIFIED ON ORDER. TORCH TIP WITH IGNITER OPENING AND BRACKET FOR FLAME ROD. BLOWER WITH AIR SCOOP.
_____	<u>2</u>	890 CONTROL BOX WITH FLAME ROD SAFETY.
_____	<u>2</u>	69 NDI FLAME ROD 12" LONG.
_____	<u>2</u>	SPARK IGNITER.
_____	<u>4</u>	14 GA., GREEN COVERED GROUND LEADS, 12' LONG WITH TERMINAL CONNECTORS.
_____	<u>4</u>	IGNITION LEADS, 12' LONG, WITH TERMINAL CONNECTORS.
_____	<u>2</u>	1" PIPE CLAMP.
_____	<u>2</u>	1/2 " X 10 3/4" PIPE NIPPLE.
_____	<u>2</u>	1/2 " PIPE COUPLING.
_____	<u>2</u>	3/8" X 12' AIR LINE WITH 3/8 COMPRESSION NUTS.

WIRING FOR TFM-1D FLAME ROD SAFETY

IN CASE OF POWER FAILURE THE FURNACE IS SHUT OFF. WHEN POWER RESUMES THE FURNACE HAS TO BE RESTARTED.
 IF THE BURNER FAILS TO LIGHT OR GOES OUT, THE GAS IS SHUT OFF IN 12 SECONDS.
 IF THE BLOWER FAILS THE GAS IS SHUT OFF.

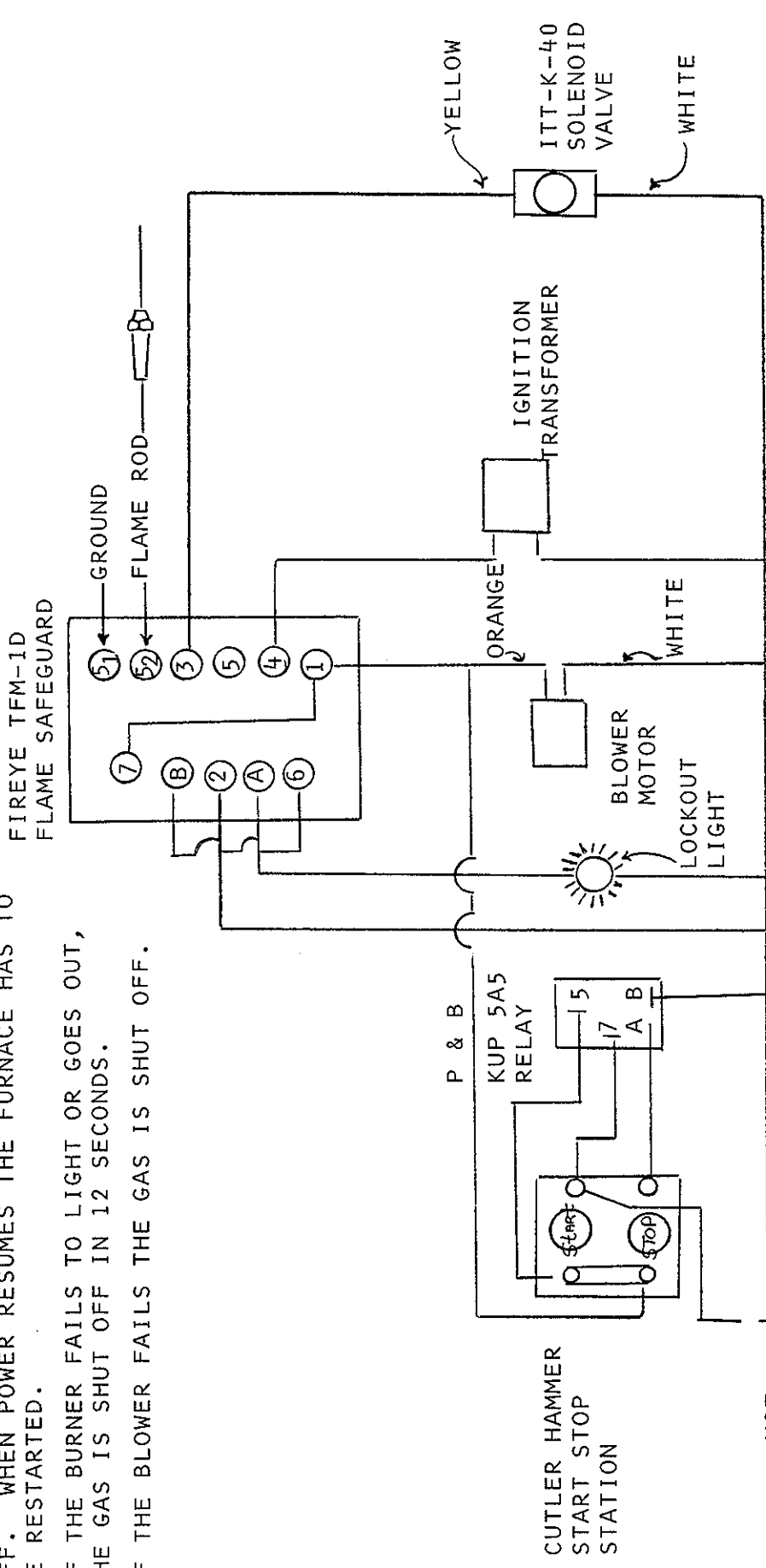

THE CUSTOMER CONNECTS 115 V. POWER SUPPLY TO BLACK & WHITE LEADS. CONNECT ORANGE LEAD TO BLACK MOTOR LEAD. CONNECT WHITE LEAD TO WHITE MOTOR LEAD. CONNECT YELLOW & WHITE LEAD TO SOLENOID GAS VALVE LEADS. IF YOU HAVE A RED OR WHITE STRIPPED MOTOR LEAD, TAPE END & DO NOT USE.

INSTRUCTIONS FOR INSTALLING INDICATING PYROMETER

1. Mount instrument mounting box on a wall or other support in a level position free of vibration.
2. A short circuiting wire or bar will be found between the terminals to protect the instrument in shipment, and must be removed.
3. A Zero adjustment screw will be found either at top or front of instrument. Using a small screwdriver, turn the screw so that the pointer indicates room temperature which can be checked by a thermometer.
4. Connect lead wires to the instrument terminals which are marked positive (+) and negative (-); the lead wires usually have a tag attached indicating polarity; if tag is not attached, proceed as above, then twist the bare wires at other end of lead wires together and hold a lighted match under the twisted joint. The instrument pointer should move up scale; if it moves down scale, reverse the connection at the instrument terminals.
5. Note the color of the covering and insulation on the lead wires; as example, if negative (-) wire is red, connect the red wire to the negative (-) terminal of the thermocouple and the other wire to the positive (+) terminal.
6. Locate hole for thermocouple and insert it into the hole.
7. Handle the thermocouple carefully and insert it through the opening in the back of a box furnace or into the pot of a pot furnace. In the event the opening in the box furnace is closed with a blank flange, this should be removed and a 1 1/6" hole through the casing will be found; if closed by the furnace lining, this can be easily drilled out to receive the thermocouple.
8. After thirty days operation again check the 0 adjustment by removing one of the lead wires at the instrument, and adjusting if necessary.

INSTALLATION OF BURN-OUT FURNACE WITH
#890 CONTROL BOX USING TFM-1D FLAME ROD SAFETY

CONSULT FORM NO. 583 -B

1. MOUNT THE #890 CONTROL BOX ON A WALL OR PANEL AWAY FROM HEAT.
2. SCREW THE PIPE NIPPLE, COUPLING AND FLAME ROD INTO THE MOUNTING BRACKET ON THE TORCH TIP.
3. CONNECT THE GROUND LEAD FROM A BOLT ON THE #890 BOX TO THE PIPE CLAMP ON THE BURNER PIPING. CONNECT GROUND LEAD FROM FIREYE CONTROL TO PIPE CLAMP.
4. CONNECT THE FLAME ROD LEAD [EXTENDING FROM THE FIREYE CONTROL] TO THE FLAME ROD ON THE TORCH TIP.
5. CONNECT THE IGNITION LEAD TO THE SPARK IGNITER IN THE TORCH TIP.
6. CONSULT THE WIRING DIAGRAM AND COMPLETE THE WIRING OF THE UNIT.
7. CONNECT THE GAS LINE TO THE GAS INLET. MAKE SURE THE PRESSURES ARE CORRECT AS SHOWN ON FORM NO. 583.
8. CONSULT THE LIGHTING INSTRUCTIONS FOR STARTING THE BURNER.

LIGHTING INSTRUCTIONS FOR BURN-OUT FURNACE
WITH NO. 890 CONTROL BOX

CONSULT FORM NO. 583 WHILE READING THIS.

1. SET GATE VALVE [LOCATED IN FRONT OF BLOWER] 1/2 OPEN. GAS ADJUSTING VALVE SHOULD BE IN THE CLOSED POSITION.
2. DEPRESS AND RELEASE THE START BUTTON. THE BLOWER MOTOR WILL COME ON AND IN ABOUT 5 SECONDS YOU WILL HEAR THE FIREYE CONTROL CONTACTS CLICK AND THE SPARK IGNITER BUZZING. YOU THEN GRADUALLY OPEN THE GAS ADJUSTING VALVE UNTIL THE BURNERS IGNITE. NOTE: IF YOU DEPRESS THE START BUTTON AND THE RED LOCKOUT LIGHT IS ON, YOU WILL HAVE TO DEPRESS THE RED RESET BUTTON THAT IS ON THE FIREYE CONTROL. THE LIGHT SHOULD GO OUT AND THE SPARK IGNITER WILL START BUZZING. YOU CAN THEN GRADUALLY OPEN THE GAS ADJUSTING VALVE UNTIL THE BURNERS IGNITE. IF YOU HAVE DEPRESSED THE RESET BUTTON AND THE LIGHT DID NOT GO OUT, WAIT ABOUT 30 SECONDS AND THEN DEPRESS THE RESET BUTTON.
3. ADJUST THE GAS VALVE TO OBTAIN THE DESIRED FLAME. TO INCREASE THE AMOUNT OF GAS, INCREASE THE BLOWER GATE VALVE OPENING IT SLIGHTLY AND THEN OPEN THE GAS ADJUSTING VALVE TO OBTAIN THE DESIRED FLAME. REPEAT THIS PROCEDURE UNTIL THE DESIRED OR MAXIMUM GAS INPUT IS REACHED.
4. TO DECREASE THE AMOUNT OF GAS, CLOSE THE BLOWER GATE VALVE SLIGHTLY AND DECREASE THE AMOUNT OF GAS TO THE DESIRED FLAME. REPEAT THIS PROCEDURE UNTIL THE DESIRED OR MINIMUM GAS INPUT IS REACHED.
5. TO SHUT DOWN THE FURNACE, DEPRESS AND RELEASE THE STOP BUTTON. THEN TURN THE GAS ADJUSTING VALVE TO THE CLOSED POSITION.

BURN-OUT FURNACE

NO. 890 CONTROL BOX - FLAME ROD SAFETY

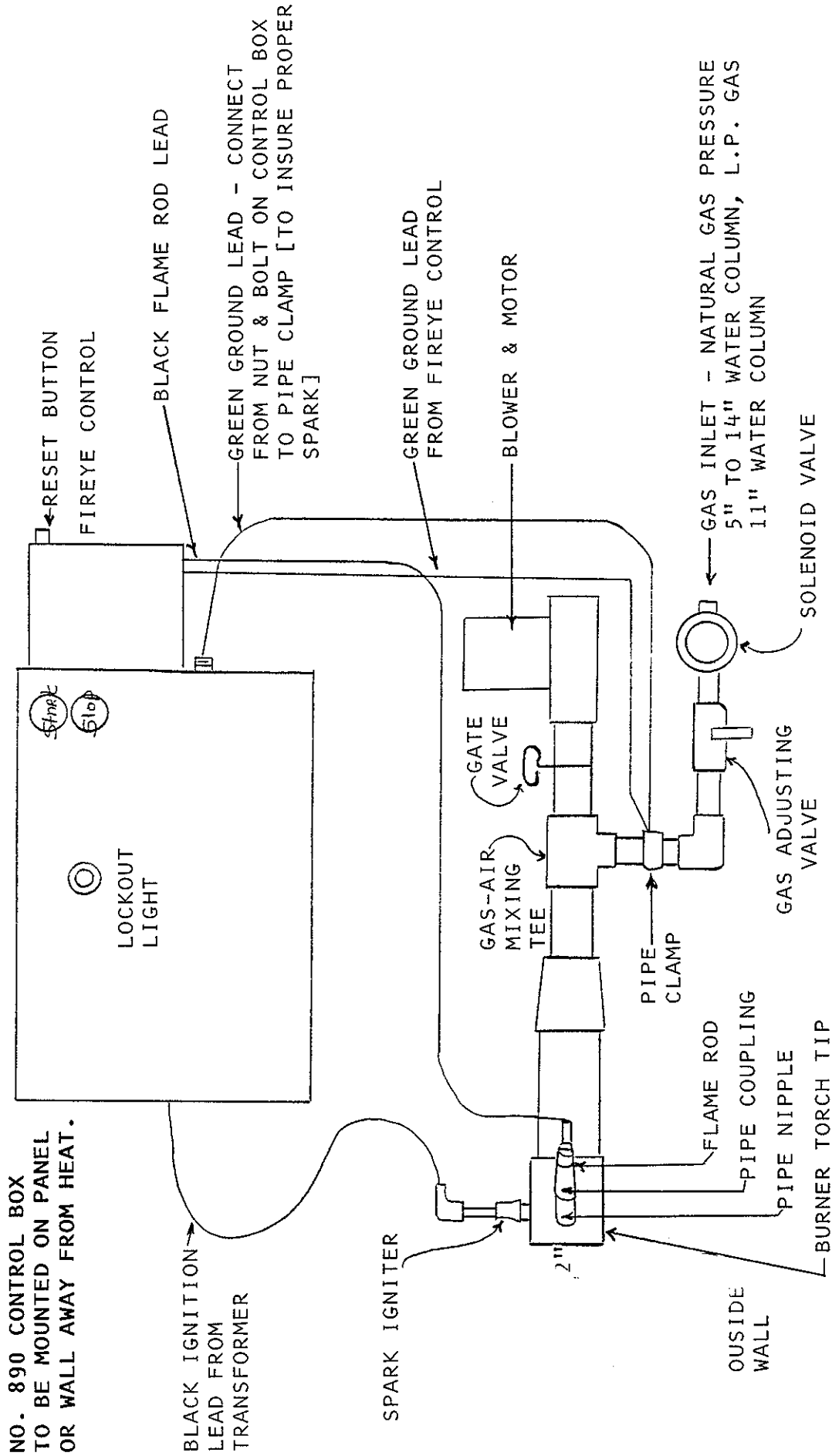

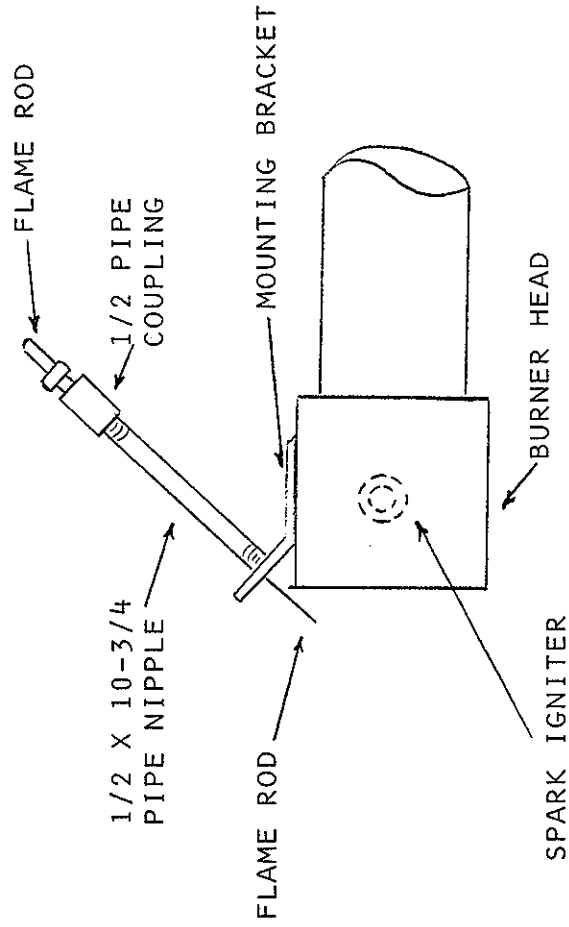

FLAME ROD EXTENDS 1-1/8" BEYOND BRACKET

NOTE: FOR CERTAIN TYPE FLAMES YOU MAY WANT THE FLAME ROD TO EXTEND INTO THE FLAME MORE. FOR THIS, THE PIPE NIPPLE CAN BE SHORTENED AND/OR THE BRACKET CAN BE BENT.

MAINTENANCE INSTRUCTIONS FOR JOHNSON FURNACES

Johnson equipment is designed to give the longest possible service at the lowest maintenance cost. Due to the high temperatures reached by Johnson furnaces certain repairs are required from time to time to keep them in good operating condition. We are listing below pertinent maintenance information.

OVEN TYPE HEAT TREATING FURNACES [#70, #120, #121, #142, #143, #654, #706]

A. GENERAL MAINTENANCE:

These furnaces are lined with high temperature insulating refractory. This refractory expands and contracts as the furnace heats and cools; and cracks will appear throughout the lining. These are normal and should not be cause for alarm and should NOT be filled with cement as it will cause the brick to spall. The door brick on the #70, #120, #121 & #654 furnaces should be replaced occasionally. It is furnished with inconel screws and washers to withstand the high temperatures. The door should NOT be used as a shelf or parts dragged across the door brick in the process of removing parts from the furnace. Also, avoid striking the sides of the furnace with tongs. The hearth plate will require replacement occasionally, as will the front and back hearth rests on which the plate is set. The hearth plate must be used with the channel edges up. Parts to be heated should be pre-heated or brought up to temperature with the furnace when possible; avoid placing a cold piece on a hot hearth plate. When the gas is turned off to the furnace, turn off the blower at once so the lining will cool gradually.

B. FURNACE RELINING AND FURNACE EXCHANGE:

The furnace should be used until the complete lining is considerably deteriorated. It should then either be replaced with a new lining or new furnace body from the factory. Complete sets of fire brick linings with special shapes to fit the furnace and cement for sealing the brick are available with easy-to-follow installation instructions. Many operators, however, prefer to take advantage of the special price on replacement furnace bodies. Check our repair parts list for prices. This method is popular because it insures an expertly relined furnace in operation at all times; it eliminates the time and trouble of relining the furnace in the customer's shop; and it eliminates the "down" time for returning to the factory for relining. WHEN ORDERING, SPECIFY IF FURNACE IS TO HAVE SAFETY PILOT PORT INSTALLED. FOR ADDITIONAL INFORMATION ON SAFETY EQUIPMENT SEE PAGE 3.

PYROMETER EQUIPMENT:

Occasional replacement must be made of the thermocouple elements, the protection tubes or of the complete thermocouple assembly. We carry replacement parts in stock for immediate delivery.

POT TYPE FURNACES [#920, #950, #568, #580, #565, #565A, #521, #575, #575A, & #575B]

A. FURNACE RELINING:

These furnaces are lined with a high-quality, wear-resistant, castable lining poured with molds used in our factory. These linings are very rugged, and the furnaces should be used until the linings are considerably deteriorated, and then replaced with new furnace bodies. The new bodies are furnished complete less blower equipment and pots or crucibles. Prices for the new bodies are given on the repair parts list. With this method the customers are assured of an expertly lined furnace; and they are never without a furnace to use in their shops. If the lid lining needs replacement before the furnace body, material can be supplied to be mixed with water and molded into the furnace lid or a refractory lid can be supplied.

B. FURNACE RELINING #900 CRUCIBLE FURNACE:

This furnace is lined with a precast lining that can be replaced in the shop or a new replacement body can be supplied.

C. USE OF POTS:

DO NOT use a pressed steel pot for melting aluminum. A graphite crucible is used in the crucible furnaces. A cast iron pot is also suitable when contamination of aluminum by the cast iron is not objectionable.

To extend pot life carry a neutral or slightly reducing flame [more gas than air]. A flame that is too blue is oxidizing and will cause rapid scaling of the pot.

Avoid infiltration of cyanide or other salts into the combustion chamber. If seepage or splashing is occurring, place a ring of dry, powdered fire clay under the flange of the pot.

Turn the pot a little each day so that a different part is exposed to the hottest gases.

Remove sludge or sediment from pot at least once a day. This acts as an insulator, causing local overheating of pot.

Remove the pot at regular intervals and thoroughly clean the inner surface. Also hammer off thin scale that forms on outside.

D. USE OF CRUCIBLES:

Crucibles should be kept in a warm, dry area. Before using a new crucible anneal it by placing it in a warm furnace and gradually raising the temperature at about five minute intervals over a period of forty five minutes until the crucible becomes red.

BLOWER MOTORS:

Motors on the blowers should be oiled occasionally. The brushes should be checked and replaced periodically to avoid wear on the armature.

FORGE FURNACES [#122 & #133]

The forge furnaces are lined with hard firebrick on all wearing surfaces. Individual firebricks can be easily replaced when desired. Lining for the lid or complete lining can be replaced when necessary. Sets of linings are furnished with simple instructions for installation.

SOFT METAL MELTING FURNACES [#379, #313 & #616]

A. FURNACE RELINING:

These furnaces can be relined with brick and castable material supplied by our Company. An instruction sheet accompanies the shipment.

B. GENERAL MAINTENANCE:

Avoid permitting metal to solidify in the pots. If the metal does "freeze" in the pot, turn one burner only on until the metal melts slowly; do not turn all burners on at once or the pot will crack. When melting metal, let small amount of metal form a molten pool before adding additional metal.

SMALL BENCH FURNACES [#101, #112, #108 & #118]

The burner tubes on these furnaces are slotted on the ends to retain the flame, and care should be taken about striking the ends with soldering irons. These tubes are made of cast iron and will give long service, but when the slots are knocked off, the tubes should be replaced to insure good combustion. The #108 and #118 furnaces are equipped with individual valves for each burner. The #101 and #112 furnaces are equipped with double valves. After considerable use the valve plugs will tighten causing the valves to "freeze". When this happens the complete valve will should be replaced as prompt replacement of the complete valve will avoid gas leakage. Linings for all these furnaces are carried in stock. Lining sets are supplied for those in which both hood and bottom are lined. This set consists of material to be molded in to the furnace body and includes a new angle iron.

APPROVED COMPONENTS FOR INDUSTRIAL FURNACES

Approved components used on our industrial furnaces and power burners with flame rod or thermocouple safety and ultra-violet safety.

JOHNSON PARTS	APPROVAL		
	UL	CSA	OTHER
Baso Switch	√		
Baso Valve		√	AGA
Baso Thermocouple			AGA
Baso Pilot w/Orifice		√	AGA
Air Switch	√		
ITT Solenoid Valve	√		Factory Mutual
Transformer	√	√	
Lock Out Light	√		
Ignition Button	√	√	
1/30 Motor Bodine	√	√	
1/7 Carter Motor	√		
1/3 Motor w/ back Contact	√		
P & B Relay	√	√	
Speed Control Switch	√	√	
Start - Stop Switch			Top/Application Only
Ignition Wire	√		
All Other Wire	√		
3/4 Gas Pressure Regulator			AGA
OJ21 Ignitor Plug	√		
Gas Adjustment Valve	√		
Fireye Control	√		
Flame Rod 12"	√		
Scanner	√		



WARRANTY

We warrant our equipment to be free of workmanship or material defects. Should any material prove defective within one year after shipment due to faulty material or improper workmanship we will furnish without charge to the original purchaser, replacement or repair of said defective part or parts returned freight prepaid to Johnson Gas Appliance Company, Cedar Rapids, Iowa. The foregoing shall not apply to equipment that has been altered or repaired after shipment to you by anyone except our authorized employees, and the Company will not be liable in any event for alterations or repairs except those made with its written consent. On material not of our manufacture, the manufacturer's guarantee to us is extended. This paragraph does not cover ordinary wear and tear, corrosion or improper handling or storage after leaving our point of shipment. If inspection by the Company does not disclose any defect in workmanship or material, the Company's regular charges will apply. Any refractories supplied with this order will be warranted as to quality and will be selected in accordance with good practice for the service intended. The foregoing obligations are in lieu of all other obligations and liabilities including negligence and all warranties, or merchantability or otherwise, express or implied in fact or by law, and state our entire and exclusive liability and buyer's exclusive remedy for any claim or damages in connection with the sale or furnishing of goods or parts, their design, suitability for use, installation or operation. We will in no event be liable for any special or consequential damages whatsoever, and our liability under no circumstances will exceed the contract price for the goods for which liability is claimed.

JOHNSON GAS APPLIANCE COMPANY • 520 E AVENUE N.W. • CEDAR RAPIDS, IOWA 52405

1-800-553-5422 • 319-365-5267 • FAX 319-365-6282

Manufacturers since 1901 / Heat Treating Furnaces / Industrial Gas Burners / Stock Tank Heaters / Concrete Curing Systems

No 34, 321, 342, 323, 345 Kiln Adjustable

Power Burner

- 75-01-00024* 1-1/2" Torch Tip with 7/8" Bore Plain
- LA-01-00104 1 1/2" Torch Tip 7/8 Bore machined for
Electric Ignition and Flame Rod Safety
- LA-01-00011* 2" Torch Tip with 1-1/4" Bore Plated
- LA-01-00002 Pilot Bunsen Burner Tube
- 05-07-00008 48" Baso Thermocouple
- 65-08-00040 #559 Thermocouple Bushing
- HA-01-00361 Thermocouple Spacer
- 65-06-00040 Ignitor Plug OJ-21-4
- 65-08-00030 Ignitor Plug Adaptor
- 65-02-00010 Washer
- 10-10-00047 Baso Switch L62GB01
- 15-01-00008 1/3 HP Motor w/Back Contact Switch
- BA-01-00002 #1203 Blower
- BA-01-00003 #1204 Blower
- 05-02-00114 1" Gate Valve
- 05-02-00113 1-1/2" Gate Valve
- 05-02-00022 1" Solenoid Valve K3A
- 05-02-00155 Straight Pilot Valve
- HA-04-00502 48" Length of Pilot Tubing
- 05-06-00014 69 NDI Flame Rod - 12" Long
- HA-04-00503 3/8" x 5' Air Line w/3/8" Compression
Nuts and Sleeves

- HA-04-00504 5' Long 14 Gauge Ground Leads
w/Terminal Connectors
- 05-06-00067 Fireye TFM-ID Flame Safeguard -
Replacement
- SA-03-00002 Flame Rod Bracket
- 05-06-00013 Fireye Base
- 05-06-00056 MP100 Programmer
- 05-06-00057 Amplifier Mart 1T
- 10-10-00071 Eaton 140-48 Air Switch
- 05-05-00001 Ignition Transformer
- 10-10-00012 P and B Kup Relay - DPDT
- 10-10-00007 Cutler Hammer 10250H-2727A Start
Stop Station
- HA-06-00254 Lock Out Light
- 05-02-00166 1" Gem Ball Valve
- 05-02-00103 3/4" Gem Ball Valve
- HA-04-00133 1-1/2" Mixing Tee
- SA-01-00077 1" Mixing Tee
- 05-02-00021 3/4" K3A Solenoid Valve
- HA-04-00514 Pilot Assy. Bunsen Type
- LA-01-00010 No. 34 Torch Stand
- HA-04-00506 Ignition Lead 5' Long w/Connectors
- HA-04-00506 Flame Rod Lead - 5' Long w/Connectors
- 10-06-00043 Ignition Boot
- 10-06-00044 Insert for Ignition Boot
- 10-06-00045 Connector for Ignition Boot
- 10-02-00002 Ignition/Flame Rod Lead Wire (per foot)

2" Plain Torch Tip
w/ 1 1/4" Bore
75-01-00025